

Hydropower Collegiate Competition

Initial Design Report

[Noah Dilworth: 1 and Executive Summary]

[Jennifer Edgar: 4.2, 4.3, and Primary Author]

[Robert Quinn Ginieczki: 3.1, 4.1, 5]

[Ben Tushingam: 2]

Fall 2024 – Spring 2025



Project Sponsor: US Department of Energy

Faculty Advisor: Dr. Carson Pete

Instructor: Dr. David Willy

EXECUTIVE SUMMARY

The Hydropower Collegiate Competition

This competition is an annual event organized by the Department of Energy, where collegiate teams work to design a hydropower system. Teams then compete in challenges designed by the event organizers to test the groups' design. Northern Arizona University sends a team to compete in this event every year, assigning the competition as a potential capstone project for interested students. At the time of writing this document, there are two sub teams: mechanical and electrical, each with four capstone students. Over the course of the fall 2024 and spring 2025 semesters, we will work together to design a hydropower system to take to the competition at the end of the academic year.

Research

In working on our project, our team has extensively researched the space of large hydropower generation system. Our first field is the raw mechanical requirements of our system, looking at material properties, mechanical part wear, and stress calculations to make certain all the mechanical parts of our system can handle the loading we expect to put them through. Second was fluid mechanical research, looking into the modern state of what hydropower and hydroelectric storage systems look like and how they operate, to give us an idea of what our system might roughly look like. Lastly, was the environmental research about how the construction of structures like what we are planning affect the flora, fauna, and landscape of the areas in which they are built. As one of the primary goals in addition to generating power is to be sustainable and environmentally conscious, it is important to us in our design that our system isn't detrimental to the environment.

Design

Our design as described by the event organizers needs to be for a structure of independent water supplies at different elevations that stores energy by pumping water to the higher reservoir and generates energy by running the water down through a turbine back to the lower reservoir. In service to this we have modeled the rough outline of our system and calculated what factors are needed for our reservoirs to have the capacity to store and generate the expected power output. Additionally, we have plans to potentially implement smaller scale solar and wind generation systems. This is both an economic and environmental measure, as doing so decreases the amount of power that needs to be imported during storage and decreases reliance on nonrenewable generation sources for that power.

TABLE OF CONTENTS

Contents

EXECUTIVE SUMMARY	1
TABLE OF CONTENTS.....	2
1 BACKGROUND.....	1
1.1 Project Description.....	1
1.2 Deliverables.....	1
1.3 Success Metrics.....	2
2 REQUIREMENTS	3
2.1 Customer Requirements (CRs).....	3
2.2 Engineering Requirements (ERs).....	3
2.3 House of Quality (HoQ).....	4
3 Research Within Your Design Space.....	4
3.1 Benchmarking	4
3.1.1 Sub-System-Level Benchmarking.....	5
3.1.2 Conclusion.....	6
3.2 Literature Review.....	6
3.2.1 Noah Dilworth.....	6
3.2.2 Robert Ginieczki.....	8
3.2.3 Jennifer Edgar.....	10
3.2.4 Benjamin Tushingham.....	12
3.3 Mathematical Modeling	14
3.3.1.1 Noah Dilworth	14
3.3.1.2 Jennifer Edgar.....	15
3.3.1.3 Robert Ginieczki.....	18
3.3.1.4 Benjamin Tushingham.....	18
4 Design Concepts.....	20
4.1 Functional Decomposition	20
4.2 Concept Generation.....	21
4.3 Selection Criteria.....	23
4.3.1 Site Selection	23
4.3.2 Power Demand	24
4.3.3 Turbine Selection.....	25
4.3.4 Conclusion.....	25
4.4 Concept Selection (Robert Ginieczki).....	26
4.4.1 Design 1:.....	28
4.4.2 Design 2:.....	28
4.4.3 Design 3:.....	29
4.4.4 Conclusion:.....	29
5 CONCLUSIONS	29
6 REFERENCES.....	31

1 BACKGROUND

The Hydropower Collegiate Competition (HCC) is an annual event sponsored by the Department of Energy (DOE) in order to engage young adults and foster interest in hydropower. The DOE also sponsors two other competitions: the Collegiate Wind (CWC) and Marine Energy Collegiate (MECC) competitions, all intent on expanding renewable energy as a field. The HCC specifically focuses on the development of energy generation and storage mechanisms primarily involving fresh water, as opposed to using wind or sea water with the CWC and MECC respectively. As the event organizers described it, “[hydropower] provides 37% of total U.S. renewable electricity generation and 93% of grid-scale energy storage,” with immense potential for expansion as energy demand grows and renewable energy goals are pushed further towards completion.

1.1 Project Description

The Hydropower Collegiate Competition for 2025 is focused primarily on the energy regulation and storage aspects of hydropower. Our goal is to design a full closed loop, pumped, hydropower storage system (PSH) with potential generation of up to 1 GW and the capacity to run for between 8 and 24 hours. This means our system will pump water between a pair of independent reservoirs that crucially do not connect to natural waterways. Using reservoirs at a height difference lets us pump water uphill to store power as gravitational potential, and to generate power the water is then run downhill through a turbine.

There are several sub competitions or “challenges” for the competition this year, all of which we intend to compete in. The Sitting Challenge involves performing a site selection process to determine where to build our project. We must decide on parameters by which to compare sites, use those to determine what location would work best for our plan, and then justify those decisions to the judges. The Design Challenge is the main engineering challenge, where we design a system for our chosen site. The Community Connections Challenge involves working with industry professionals and outside groups to better develop our project and/or work to increase interest in hydropower. The Build and Test Challenge is primarily modeling and prototyping, developing a model of our system for communicative and display purposes. Last is the Cyber in Hydro Challenge, which is the newest of the challenges in the HCC. This involves us assessing cybersecurity threats to our system and modifying our design to account for such vulnerabilities.

1.2 Deliverables

For our project, the deliverables stem from either the capstone class or the collegiate competition with significant overlap in work that goes into the design but mostly different final submissions. As an example, there are two prototyping assignments for capstone this semester, as well as the Build and Test Challenge for the competition. The prototyping assignments are focused more on developing a minimum viable product, working out the specifics of subsystems within the greater design and presenting that work to the team, which are spread throughout the first semester. The Build and Test Challenge is one of the competition events that will be held sometime in the spring semester. As a result, the plan is to use those class deliverables to work on parts of the final challenge deliverable as the semester continues.

For capstone, we have several known deliverables for the fall semester which have been public from the start of semester. We have weekly timecards and staff meeting assignments meant to track our progress, what contributions individuals have made to the team, and how much time has been spent on the project. We have two reports, of which this document is the first, outlining the current state of our project. There

are website checks, as building a website through NAU is one of the expectations for all capstone projects. There are also presentations, meant to show the team's work to the rest of our capstone section, which have specified content sometimes requiring additional work to assemble and which are followed by evaluation assignments done as individuals to review and potentially critique the self, the individual's team members, and the other teams that presented. Lastly there are the end of semester deliverables, mainly the final design submissions as well as a pair of extra credit assignments for attending the second semester capstone teams' presentations and filing a course evaluation form.

For the competition, we have significantly fewer assignments. Most of the deliverables are events that we as a team need to attend. There are periodic zoom meetings held by the competition organizers to allow us to meet with them to ask questions and that allow them to give us more information on the project. There are also two in-person conferences, both of which we plan on attending. The first is in Boulder, Colorado November 9th through 10th, named the 'STEMapalooza'. Here, teams are invited to meet, discuss the competition with industry professionals, and enjoy a weekend of science and fun. The second event will be held in March 2025. This is where the final submissions of all of the challenges each team have attempted will take place, and where the results will be announced. Last is a mid-year submission document outlining our progress to the event organizers, meant to quantify our progress and which is worth 20% of the final points for the competition and this is due on January 27th.

There are also some meetings and assignments we as a group are undertaking to improve our project that don't cleanly fit into either of the above categories. First are our weekly team meetings where the mechanical and electrical sub teams meet with Professor Carson Pete, our faculty advisor, to discuss our progress, receive advice, organize team activities, and plan for the future. Second are our meetings with Energy Club. We have at least one team member attending every meeting with more members often going for larger activities. One of the primary drivers of this was the Community Connections Challenge for the HCC, as the energy club is where all three of the DOE sponsored groups have agreed to meet. We currently are working on a proposal to receive funding from the Jacks Green Fund to build a mobile green energy system in order to engage our peers and educate them on how green energy systems work. We also have plans to work with Willow Bend, an organization focused on teaching the younger generation about science and the environment, to help them with some of their work and help with one of their 'Science Saturdays' in February, which will be focused on water and wind energy.

1.3 Success Metrics

We have three main goals for this project: design the best system we can, get A's in the capstone class, and place first in the competition. To this end, the metrics of our success are mostly straightforward. Success in achieving good grades in the capstone classes is extremely quantifiable: did we receive A's or not. We also can track this over time by seeing what grades we received for individual submissions and using those as metrics for the quality of our work. The third is somewhat harder to quantify, taking first place in the competition, but we will ultimately still have a definite answer: yes or no. The difficulty stems from not having metrics before the very end to quantify our progress. Last is the first goal: design the best system we can. Outside of the above metrics and asking industry experts for their opinions, the only way to achieve this is to do our best, put in hard work, and hope we succeed.

2 REQUIREMENTS

To design a closed loop PSH system hitting all of the success metrics from above some basic customer and engineering requirements were formed. To hit the success metrics outlined, the team carefully selected engineering requirements and the customer requirements to quantitatively show the most important parts to focus on.

2.1 *Customer Requirements (CRs)*

There are 4 main customer requirements, power production, environmental impact, site feasibility, and community engagements. Starting with the customer requirements, the proposed system must be able to produce up to 1 GW of power, and it must be able to run for 24 hours. This means the site that is chosen must have enough head and flow rate to produce 1GW of power, while still being able to produce enough power for 24 hours to have a company like SRP buy the power from the site. The second customer requirement is keeping the environmental impact as small as possible. The goal is to make the environmental impact of the system be or get as close to 0 as possible. The third customer requirement is site feasibility. This ties back into power production, but instead of having the required amount needed it will represent the power demand in the area or potential power that needs to be replaced. It looks at how close the system is to power lines, and if those power lines have a need for the power the site will produce. The fourth is community engagement. A big part for our customers is getting the community involved in renewable energy, so presentations to primary schoolers and even sharing renewable energy to first-year students at NAU is a big part of the project.

2.2 *Engineering Requirements (ERs)*

From those customer requirements, we produced engineering requirements that are quantitative. We have 5 engineering requirements energy output, environmental impact, efficiency, social/community impact, and site location. The first requirement is energy output. The best energy output score is achieved at 1GW, and the higher the score, the closer to 1 GW the system's max power output is. The second requirement is environmental impact. For PSH systems to be accepted, they must show they do not impact the environment. The lower the percent of environmental impact to the land from before and after the design is implemented is what determines this score. The closer to 0%, the higher the weight for this category. The next is efficiency, efficiency is based on the power the system can produce up to 24 hours of work, and that the system is producing up to or a little less energy than the grid it goes onto can hold. Engineering requirement number 4 is social/community impact. For this the group is looking at the amount of people that can be affected by the project, like a well-designed website or outreach projects to attempt to instruct people about PSH systems. The competitiveness requirement weighs all the final grades that the competition looks for and translates it to the requirements made by the team. The last requirement is the site location requirement which looks at the distance from the energy production plant to the transmission line the system will be set up to. The lower the number, the greater the number of points.

2.3 House of Quality (HoQ)

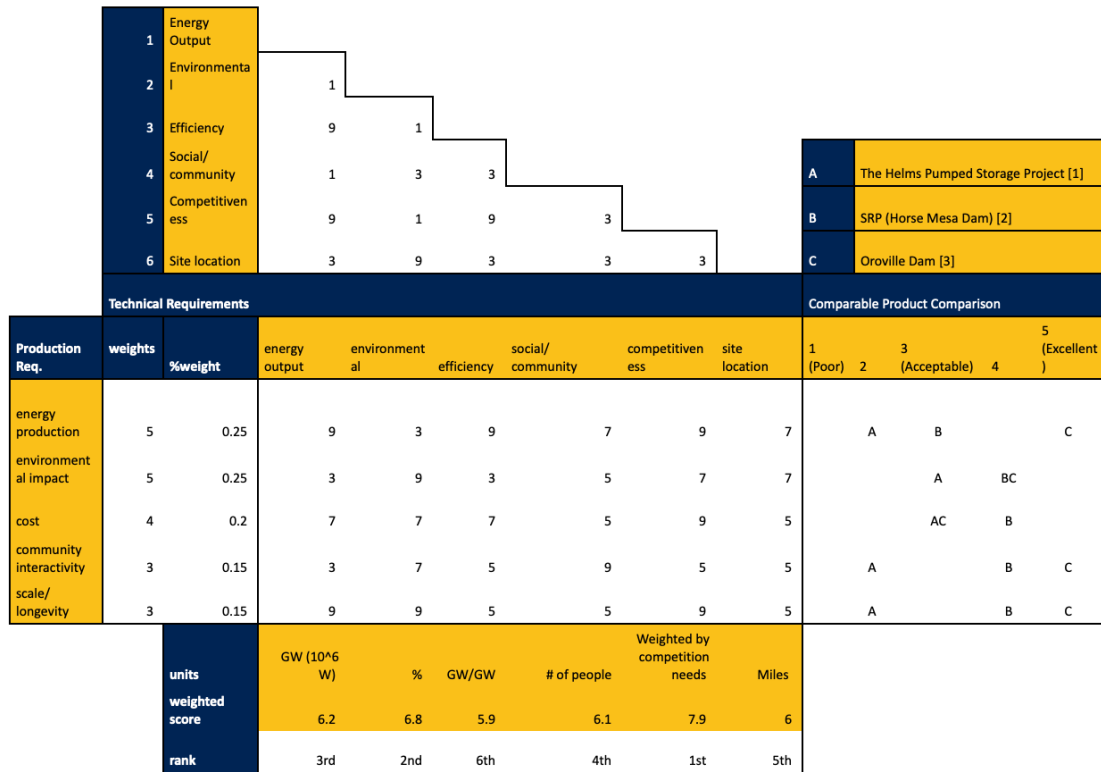

Figure 1: HoQ

By comparing the engineering requirements to each other, our team found competitiveness is the most important in regard to our competition. Then most important to least important is the environmental impact, energy output, community outreach, site location, and efficiency respectively.

3 Research Within Your Design Space

3.1 Benchmarking

1. Swan Lake Closed-Loop Pumped Storage Hydro Facility

The Swan Lake Energy Storage Project exemplifies modern advancements in pumped storage hydropower. Located in Klamath County, Oregon, this facility operates as a closed-loop system, meaning it is not reliant on natural water bodies, which minimizes its environmental footprint. The project has a storage capacity of 9.5 hours and is capable of generating 393 MW of power, providing energy for around 125,000 homes in the Pacific Northwest. This facility is designed to complement renewable energy sources, like wind and solar, by storing excess energy during periods of low demand and releasing it when energy demand increases. Additionally, the proximity of Swan Lake to existing transmission lines, such as the Pacific AC Intertie, ensures efficient power distribution across the region. The project also

supports local economic growth by creating jobs and increasing tax revenue for the county, further positioning it as a vital player in the region's clean energy transition [32], [33].

2. Goldendale Pumped Storage Project

The Goldendale Pumped Storage Project, positioned near the Oregon-Washington border, is another large-scale example of cutting-edge pumped storage technology. With a storage capacity of up to 12 hours and an ability to generate 1,200 MW of electricity, Goldendale is designed to support the grid by storing renewable energy, particularly from wind and solar sources, when generation exceeds demand. This energy can then be dispatched during peak demand periods, helping to balance the grid. The system's large-scale capacity and strategic location near transmission infrastructure makes it an essential project for the region's renewable energy strategy, contributing significantly to both state and regional energy goals [34], [36].

3. Helms Pumped Storage Project

The Helms Pumped Storage Project, located in California, serves as a critical energy stabilizer for the state's grid, especially while renewable energy sources like solar and wind play an increasingly larger role. With a generation capacity of 1,200 MW, Helms efficiently stores and releases energy by cycling water between two reservoirs. This flexible system can quickly respond to changes in demand, making it essential for grid reliability. Helms' ability to store renewable energy when production is high and release it during peak demand showcases its significance in California's ongoing renewable energy transition [33], [36].

3.1.1 Sub-System-Level Benchmarking

Turbine Efficiency

The turbines used in modern closed-loop pumped storage systems, such as Swan Lake, Goldendale, and Helms, are designed for maximum energy efficiency. These advanced turbines are critical in converting the potential energy stored in the water into electricity with minimal losses. Swan Lake, for example, features highly optimized turbines that ensure efficient power generation, even during low water flows, while maintaining operational efficiency throughout the energy storage and generation cycle. Goldendale and Helms similarly employ high-efficiency turbines, ensuring that both facilities can provide reliable energy output during periods of peak demand. Employing high-efficiency turbines enhances the overall performance of these projects [32], [33].

Reservoir and Water Management

Effective water management systems are a defining characteristic of closed-loop facilities. Swan Lake, in particular, utilizes two man-made reservoirs—one at a higher elevation and one at a lower elevation—to efficiently cycle water without impacting natural water bodies. This closed-loop design reduces environmental concerns and ensures sustainable water use. Goldendale and Helms use two-reservoir systems that recycle water between the upper and lower reservoirs, reducing the need for additional water and mitigating environmental impact. This approach allows these projects to efficiently store renewable energy while remaining environmentally responsible [34], [36].

Renewable Energy Integration

A key feature of these pumped storage facilities is their seamless integration with renewable energy sources like wind and solar. Swan Lake captures excess renewable energy during periods of low demand, using it to pump water to the upper reservoir. This energy can then be released as needed to generate electricity when demand is higher, providing a buffer for the intermittency of renewable sources. Goldendale operates similarly, storing surplus wind energy during low-demand periods and releasing it during high-demand times. These systems help smooth out the variability of renewable energy, making the grid more reliable and reducing the reliance on fossil fuels [32], [35].

Transmission and Grid Connectivity

Efficient connection to the existing energy grid is essential for the success of large-scale energy storage projects like Swan Lake and Goldendale. Swan Lake's proximity to high-voltage transmission lines, such as the Pacific AC Intertie, enables the facility to deliver stored energy quickly and efficiently to meet regional electricity needs. Goldendale also benefits from its strategic location near existing transmission infrastructure, ensuring that stored energy can be dispatched to the grid with minimal delays. This close connection to the grid enhances the value of these facilities as reliable sources of on-demand renewable energy [33], [36].

3.1.2 Conclusion

By benchmarking key projects such as Swan Lake, Goldendale, and Helms, it is clear that modern closed-loop PSH systems provide essential solutions to the challenges posed by renewable energy variability. These systems, through their efficient turbines, advanced water management designs, and strong grid connectivity, ensure the reliability and sustainability of renewable energy. They are vital components in the ongoing transition toward cleaner, more resilient energy grids.

3.2 Literature Review

3.2.1 Noah Dilworth

[1] W. D. Caster Jr., D. G. Rethwisch. "Material Sciences and Engineering". Danvers, MA: McGraw-Hill Education, 2000. ISBN-13: 9781119321590

The specific sections of this textbook we are using are chapters 16, 17, and 19, which cover mechanical, thermal, and electrical properties for composite. This is important for our project because much of our construction will likely be done using concrete, a composite. As a result, we will need to use those material calculations in determining the exact composition of any concrete members or sections of our final design.

[2] R. G. Budynas, J. K. Nisbett. "Shigley's Mechanical Engineering Design". New York, NY: John Wiley and Sons, Inc., 2020. ISBN-978-0-07-339821-1

This textbook has a plethora of information relating to material stress, strain, and wear calculations for parts of almost every conceivable geometry. Of the greatest importance to our project are parts 2

and 3 of this textbook, which focus on stress and failure calculations. Because of the nature of our project, much of the wear our parts endure will be done by cyclical loading, which decreases the maximum tolerable loads a part can handle over time. As a result, the life expectancy and wear calculations will be important in designing parts not just to make certain they can endure the forces we expect them to take but also in determining how many cycles a part can endure before needing to be replaced.

[3] Y. Liu, T. Yen, T Hsu. "Abrasion erosion of concrete by water-borne sand". Cement and Concrete Research, vol. 36, issue 10,

This paper describes the effects of how small, hard particulate like sand when suspended in water can wear away artificial structures, mainly those made of concrete. This is an important source to consider in designing our machinery and reservoirs because unexpected changes in the internal geometry of our systems could severely impact the overall system's ability to function. With this information, we can determine if we potentially need additional mechanisms to purify the water in our system and plan for wear done to our concrete structures.

[5] N. Hao, X. Li, Y. Li, J. Jia, L. Gao. "A novel reliability-based method of calibrating safety factor: Application to the cemented sand and gravel dams". Engineering Geology, vol. 306, 2022, ISSN 0013-7952, <https://doi.org/10.1016/j.enggeo.2022.106719>.

Our project, though not technically being a dam, will need to consider many of the same potential dangers to its integrity. Both being large scale hydropower megastructures will mean that many of the same types of stresses, wear, and erosion apply to both dams and our pumped hydropower storage system. This paper outlines a theoretical way to determine the factor of safety for parts of our structure, which is important in determining the viability of a potential design. Though not our only metric, the equations from this paper will be another tool we can use to determine if our design is as reliable and safe as it needs to be.

[6] E. Sayed-Ahmed, A. Abdelrahman, R. Embaby. "Concrete dams: thermal-stress and construction stage analysis". Dams and Reservoirs, vol. 28 issue 1, pp. 12-30. March, 2018. E-ISSN 1756-8404. [Online]. Accessed September 15, 2024. Available: <https://doi.org/10.1680/jdare.16.00055>

A potential source of danger with our system is in the actual construction of our system. As mechanical engineers it is easy to forget about the manufacturing something when optimizing for its functionality and building with concrete is potentially very hazardous. As outlined in this paper, because making concrete involves an exothermal chemical reaction, construction needs to be done in stages. The heat isn't evenly distributed, but rather is gradient throughout the structure, causing localized areas of higher or lower pressure if improperly set, which can drastically decrease the mechanical strength of the material. As such, if construction of our structure were planned, we would need to account for these processes, potentially also needing design changes to make the manufacturing process more feasible.

[7] Y. Ghanaat. "Failure Modes Approach to Safety Evaluation of Dams". 13th World Conference on Earthquake Engineering, Vancouver, CA, paper no. 1115. Accessed Sept. 15, 2024. [Online]. Available: <http://queststructures.com/publications/13WCEE-Paper.pdf>

This is a paper from the 2004, but it outlines many important secondary dangers to hydro structure integrity: earthquakes, erosion, and other complex phenomena that could endanger the integrity of our system. If time permits, it would be ideal to consider the potential natural threats to the integrity of our system, but at present it is unknown if time will allow for that, and our current plan is to build somewhere in the northwest or southwest where earthquakes, tornados, and hurricanes are extremely uncommon.

[8] J. Laue, and S. Knutsson, 'Dam Safety and Dams Hazards', Journal of Earth Sciences and Geotechnical Engineering,, vol. 10, no. 6, pp. 23–40, 2020.

In addition to having a great name, this paper looks at the less quantifiable impact of how the construction of a hydropower megastructure impacts local communities. This as another tool for site selection will be important as one of the most important secondary considerations of the competition is the social impact of our design.

3.2.2 Robert Ginieczki

[25] F. A. Diawuo and R. T. Amanor, "Need for pumped hydro energy storage systems," in Pumped Hydro Energy Storage for Hybrid Systems, A. T. Kabo-Bah, F. A. Diawuo, and E. O. Antwi, Eds. Academic Press, 2023, pp. 23-41. doi: 10.1016/B978-0-12-818853-8.00001-7

This book chapter explores the growing necessity of pumped hydro energy storage systems in the context of modern renewable energy grids. The authors highlight how these systems are critical for managing the intermittency of wind and solar energy, helping to stabilize electricity grids. For our capstone project, which involves developing a closed-loop pumped storage hydropower system, this reference provides a solid theoretical foundation by explaining why such systems are vital in sustainable energy practices and grid resilience.

[26] Federal Energy Regulatory Commission, "Final Environmental Impact Statement for the Mountain Valley Pipeline Project," Federal Energy Regulatory Commission, Jan. 25, 2019. [Online]. Available: <https://www.ferc.gov/sites/default/files/2020-06/01-25-19-FEIS.pdf>. [Accessed: Sep. 16, 2024].

This final environmental impact statement reviews the ecological consequences of constructing the Mountain Valley Pipeline. While its focus is on pipeline infrastructure, the regulatory and environmental considerations it discusses are pertinent to our project, particularly in terms of understanding how large infrastructure projects, like a pumped storage facility, must comply with

environmental standards. The insights gained from this document will guide the environmental assessment and regulatory compliance aspects of our design.

[27] Voith, "Francis Turbines," Voith, 2018. [Online]. Available: https://voith.com/corp-en/VH_Product-Brochure-Francis-Turbines_18_BDI_VH3369_en.pdf. [Accessed: Sep. 16, 2024].

This technical brochure by Voith outlines the specifications and performance characteristics of Francis turbines, a key component used in pumped storage hydropower systems. For our project, this reference provides critical information on the operational capacities and design parameters of Francis turbines, which are essential for evaluating their application in our closed-loop storage system. The material will assist in selecting the right turbine model to optimize efficiency and power generation in our design.

[28] Federal Energy Regulatory Commission, "Final Environmental Impact Statement for the Mountain Valley Pipeline Project," Federal Energy Regulatory Commission, Jan. 25, 2019. [Online]. Available: <https://www.ferc.gov/sites/default/files/2020-06/01-25-19-FEIS.pdf>. [Accessed: Sep. 16, 2024].

This article focuses on techniques for expanding the operating range of Francis turbines by detecting instability early, thereby enhancing energy production. By implementing advanced monitoring systems, the authors show how operational challenges can be mitigated before they affect performance. This research is highly relevant to our project as it provides insights into improving the operational stability of Francis turbines, a key component in our closed-loop system, ensuring reliable performance during variable operational conditions.

[29] U.S. House of Representatives, "Report on the Activities of the Committee on Energy and Commerce for the One Hundred Fifteenth Congress," U.S. Government Publishing Office, Washington, DC, Rep. 115-458, 2018. [Online]. Available: <https://www.govinfo.gov/content/pkg/CRPT-115hrpt458/pdf/CRPT-115hrpt458.pdf>. [Accessed: Sep. 16, 2024].

This report presents an overview of the legislative and policy discussions regarding energy infrastructure in the U.S. Congress during its 115th session. It provides important context on the regulatory landscape for energy projects. This is directly relevant to our project, as it helps us navigate the policy environment surrounding renewable energy initiatives and energy storage systems like our proposed pumped storage facility. The document will guide us in understanding potential regulatory hurdles and opportunities in our project.

[30] "Design features of the Helms pumped storage project," IEEE Xplore, pp. 10-12. [Online]. Available: <https://www.ieee.org>. [Accessed: Sep. 16, 2024].

This document describes the engineering and operational details of the Helms Pumped Storage Project, one of the largest projects of its kind in the U.S. It details the design challenges, engineering solutions, and operational outcomes of the facility, which directly informs the design phase of our project. Learning from the Helms project provides practical insights into optimizing design and ensuring the efficient operation of a pumped storage system, which will help refine our approach to developing a closed-loop facility.

[31] N. Fitzgerald, R. Lacal Arántegui, E. McKeogh, and P. Leahy, "A GIS-based model to calculate the potential for transforming conventional hydropower schemes and non-hydro reservoirs to pumped hydropower schemes," *Energy*, vol. 41, no. 1, pp. 483-490, 2012. doi: 10.1016/j.energy.2012.02.044. [Accessed: Sep. 16, 2024].

This paper presents a geographical information system (GIS)-based model to evaluate the feasibility of converting traditional hydropower plants and non-hydro reservoirs into pumped storage facilities. It outlines the process of site selection based on geographical and technical factors. For our capstone project, this methodology is highly applicable as we are also exploring suitable locations for a closed-loop pumped storage facility. The GIS-based approach in the paper offers a model for assessing the viability of potential sites, ensuring the technical feasibility of our project location.

3.2.3 Jennifer Edgar

[9] F. M. White and H. Xue, *Fluid Mechanics*. New York, NY: McGraw-Hill, 2021

This textbook includes a chapter about turbomachinery that produces many different equations surrounding turbines. Within Chapter 11, there are example problems that may be like future calculations for our project. The Euler turbine equation is in this chapter, and this is used widely to calculate the power output. This textbook offers multiple different equations for different turbine types that will be useful in determining power output and turbine efficiency.

[10] P. Breeze, "Chapter 8 - Hydropower," in *Power Generation Technologies (Second Edition)*, Newnes, 2014, pp. 153–179

This book describes the three different turbine types that our team is considering. This book chapter includes helpful information about the different turbines and when they are implemented. The three being Francis, Kaplan, and Pelton. Francis and Kaplan are reaction turbines while the Pelton turbine is an impulse turbine. The reaction turbines use both kinetic and pressure energy while impulse turbines use only kinetic energy from the water. The book also incorporates the head, and pressure amounts that are associated with each turbine.

[11] J. I. Pérez-Díaz, M. Chazarra, J. García-González, G. Cavazzini, and A. Stoppato, “Trends and challenges in the operation of pumped-storage hydropower plants,” *Renewable and Sustainable Energy Reviews*, vol. 44, pp. 767–784, Apr. 2015. doi:10.1016/j.rser.2015.01.029

This paper discusses hydropower in the aspect of hybrid designs. This paper talks about the pros and cons of using storage hydropower in addition to solar and wind specifically. This paper also has some information on the electrical side of how to incorporate the designs in the electrical side.

[12] T. R. Simon *et al.*, “Life cycle assessment of closed-loop pumped storage hydropower in the United States,” *Environmental Science & Technology*, vol. 57, no. 33, pp. 12251–12258, Aug. 2023. doi:10.1021/acs.est.2c09189

This paper is going to be useful further down the line in our project as it discusses the environmental effects of the hydropower systems on the site location. It provides equations to help predict the effects of the system on the surrounding areas. When comparing the designs these equations will be helpful to see what systems and design concepts will be the best in regard to the environment.

[13] C. Trivedi, M. Cervantes, and O. Dahlhaug, “Experimental and numerical studies of a high-head Francis Turbine: A review of the Francis-99 Test Case,” *Energies*, vol. 9, no. 2, p. 74, Jan. 2016. doi:10.3390/en9020074

This paper does a study on the Francis turbine specifically. In hydropower the favored turbine is the Francis turbine, and this breaks down different components of the turbine in a real-life study. There are equations that are specific to the Francis turbine that may be beneficial when trying to decide between which to choose.

[14] E. Engineeringtoolbox, “Hydropower,” Engineering ToolBox, https://www.engineeringtoolbox.com/hydropower-d_1359.html (accessed Sep. 14, 2024).

This is an engineering tool/website that provides different equations for turbines. It describes how to calculate theoretical and actual power. These equations were used in mathematical modeling for the three different turbine types.

[15] “Types of hydropower turbines | Department of Energy,” Department of Energy, <https://www.energy.gov/eere/water/types-hydropower-turbines> (accessed Sep. 15, 2024).

This is the department of energy’s website that talks about the different types of turbines used in hydropower. It describes impulse and reaction turbines and the different types of reaction and impulse turbines. It also includes helpful information about which turbine has adjustable components, and which are used for higher/lower head and higher/lower water pressure.

[16] D. Smith, J. Hartmann, and R. Kvam, “Hydropower Communications and consultation,” Hydropower Sustainability Alliance, (accessed Oct. 20, 2024).

This is an international publication that is in the process of becoming an official standard it seems. This source covers everything from societal impacts the technical analysis. This publication is going to be a big help in understanding the key importance of who is affected by our design and more of the societal impacts that often engineers don’t consider right away. It also discusses the different approaches into how the methodologies work and the appropriate planning for hydropower sites.

3.2.4 Benjamin Tushingham

[9] F. M. White and H. Xue, Fluid Mechanics. New York, NY: McGraw-Hill, 2021

There are multiple useful parts to this book, but the most important parts are Chapter 4 and 5. The go over pipe flow and flow and forces in big reservoirs with no rivers coming in nor out, matching the proposed reservoirs for our system. This will help us calculate the forces acting on all the pipes from the liquid along with the velocity going into the penstock from the gravity acting on the water above it.

[18] B. C. Punmia, Ashok Kumar Jain, and Arun Kumar Jain, Soil mechanics and foundations. Delhi: Laxmi Publications (P) Ltd., , C, 2005.

After reservoirs are designed, the soil and other materials near the reservoir site will have to be

investigated. Looking at how those materials interact with water and the effect of us building a reservoir are big parts of environmental impact. This book has done multiple studies on how varied materials act when soaked in water and their different properties, showing parts of the different effects that the reservoir can have on the surrounding soil/environment.

[19] “Closed-Loop Pumped Storage Hydropower Resource Assessment for the United States Final Report on HydroWIRES Project D1: Improving Hydropower and PSH Representations in Capacity Expansion Models,” 2022. Available: <https://www.nrel.gov/docs/fy22osti/81277.pdf>

This study published by NREL shows the different data and variables that are considered when doing site selection and shows the possible Closed Loop Sites in the United States. The paper also goes over other important materials, like different cost in the building part, like the amount to excavate a reservoir based off size, tunneling cost for penstock and more.

[20]“2021 Pumped Storage Hydro Report,” 2021. Available: 2021-Pumped-Storage-Report-NHA.pdf (hydro.org)

This paper goes into hydropower as an energy source against other energy sources like solar and coal. IT shows that the biggest batteries are in Pumped Storage Hydropower. Th paper also starts going into the cost of electricity and states that are looking to meet sustainable energy goals by certain years. That helps with site selection and shows which states need and want a system like a PSH system.

[21] S. Lake, “FINAL ENVIRONMENTAL IMPACT STATEMENT FOR HYDROPOWER LICENSE,” 2019. Accessed: Sep. 17, 2024. [Online]. Available: <https://www.ferc.gov/sites/default/files/2020-06/01-25-19-FEIS.pdf>

This paper goes over the environmental test done by a closed loop PSH system being developed. This is great as the biggest reason PSH systems are not more common is because of the environmental impact. This is a great guide to what we need to look for and the important parts of the environment that can help us design the system.

[22] “Federal Energy Regulatory Commission Engineering Guidelines for the Evaluation of Hydropower Projects,” 2017. Accessed: Sep. 17, 2024. [Online]. Available: <https://www.ferc.gov/sites/default/files/2020-04/Chap14AppendixH.pdf>

These guidelines are for the construction of hydropower storage and reservoirs. The system created needs to abide by all these regulations for the project to be considered feasible.

[23] “Bath County Pumped Storage Station | Dominion Energy,” [www.dominionenergy.com.
https://www.dominionenergy.com/projects-and-facilities/hydroelectric-power-facilities-and-projects/bath-county-pumped-storage-station](https://www.dominionenergy.com/projects-and-facilities/hydroelectric-power-facilities-and-projects/bath-county-pumped-storage-station)

Bath County Pumped Storage Hydro is the largest Pumped storage Hydro plant in the United States. This website has links to all their resources. This will be a useful resource to compare our project to one of the leading PSH systems in the United States.

3.3 Mathematical Modeling

3.3.1.1 Noah Dilworth

One of the crucial pieces for mathematical modeling is calculating the applied loads and stresses being applied to the different parts of our system and making sure that our chosen materials can not only withstand those stresses, but also that the parts can withstand the wear of continuous use. The basic formula for calculating stress (written below as equation 1) describes stress as the ratio of force over area.

$$\sigma = \frac{F}{A} \quad [1]$$

This equation has several modifications, but note are the conversions to stress due to pressurized fluids (below as equation 2). This is an important step because the basic mechanisms of our system rely on pressurizing fluid and using machinery to convert between potential, kinetic, and internal energy to electricity. Equation 2 specifically describes the stress in a cylinder as being a function of the difference in pressure between the inside and outside of the pipe multiplied by the radius of the pipe at the point of interest divided by the total thickness of the wall t .

$$\sigma = \frac{pr}{t} \quad [2]$$

Without specific geometries yet, we cannot calculate values for any of these. When we have specifics, these will be used for material selection, where any given material will have a known max strength before yielding that we will use to design our parts. That material strength will then determine the factor of safety for that part or component, below as equation 3, describing the safety factor as the value of the maximum tolerable stress divided by the expected applied stress.

$$S_f = \frac{\sigma_{yield}}{\sigma_{applied}} \quad [3]$$

The output of the safety factor formula gives a dimensionless constant. This describes how far over the

minimum tolerable strength we need to be. This value is what we need to ultimately calibrate for, with expected values being around 1.5 or 2 for most mechanisms, and needing to be around 3 or 4 for mechanisms where failure would be catastrophic, such as the wall of a dam collapsing.

There are also additional calculations for determining material where, that describe the maximum tolerable strength of a material after cyclical loading as a function of it's initial strength and decreasing with increasing numbers of cycles, but the formulas for those calculations are highly material dependent.

3.3.1.2 Jennifer Edgar

Most of my mathematical modeling has been centered around turbine solution and calculations. The first part of the mathematical modeling is calculating the potential power available from each of the three turbines we are considering.

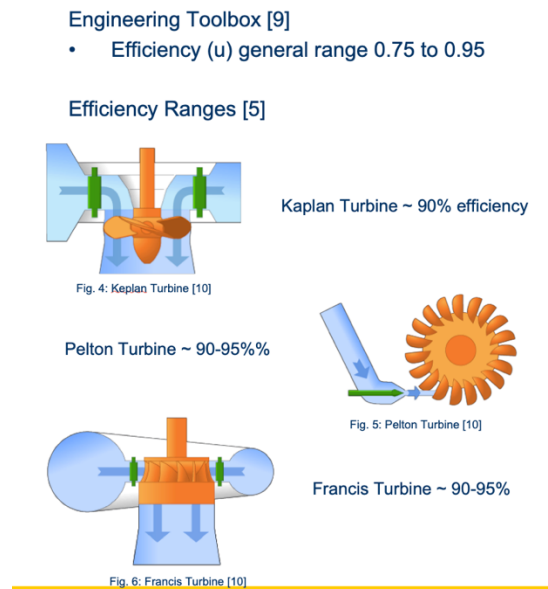

Figure 2: Turbine Types with Efficiency

$$P_a = \eta \cdot \rho \cdot q \cdot g \cdot h \quad [4]$$

$$P_a = 0.9 \cdot 1000 \frac{kg}{m^3} \cdot 1000 \frac{m^3}{s} \cdot 9.81 \frac{m}{s} \cdot 9.81 \frac{m}{s^2} \cdot 100m$$

$$P_a = 882,900,000 \frac{kg \cdot m^2}{s^2} = W$$

The P on the left is power available. The other variables are efficiency, density of water, water flow, gravity, and head amount respectively. In equation 4 it is assumed an average efficiency of 90% for each of the three turbine types. The density of water is always going to be $1000 \frac{kg}{m^3}$. The flow rate of water, based on another team members calculation, should ideally be around $1000 \frac{m^3}{s}$. The gravity is $9.81 \frac{m}{s^2}$ and

the head height should be ideally 100 m. Using these values, we get an available power of about 882,900,000 W and we need up to 1,000,000,000 W. This is a good estimate for us to consider how much our hybrid design needs to compensate for. This would also be around an ideal situation because our team always knew that the hydropower system was not going to compensate for the whole amount of power.

The next mathematical model is determining the turbine types inside of a Matlab program. When considering site selection, turbine type is particularly important, but if we are evaluating 1,000 different sites, we would not want to work out the turbine power output for all 3 of the turbines 1,000 times. The Matlab program allows us to plug in the values of each site and have it produced the power output and efficiency of each of the three turbines to view which turbine would be the most efficient for each site. For the power output, Euler’s Turbine Equation was used for the calculations.

$$P = \omega \dot{m} \cdot ((v_c \cdot r_c) - (v_b \cdot r_b)) \quad [17] \tag{5}$$

Equation 7 is Euler’s Turbine equation which produces power in watts. The right side of the equation is angular velocity, mass flow rate, tangential fluid velocity at outlet, radius of the inner turbine portion, tangential fluid velocity at inlet, and radius of the outer turbine portion respectively. Then using a basic efficiency equation of :

$$\eta = \frac{P_{actual}}{P_{max}} \tag{6}$$

Equation 8 uses the power produced by each turbine divided by the maximum power of each turbine (efficiency is 100%). For a visual the following are the inputs and the outputs:

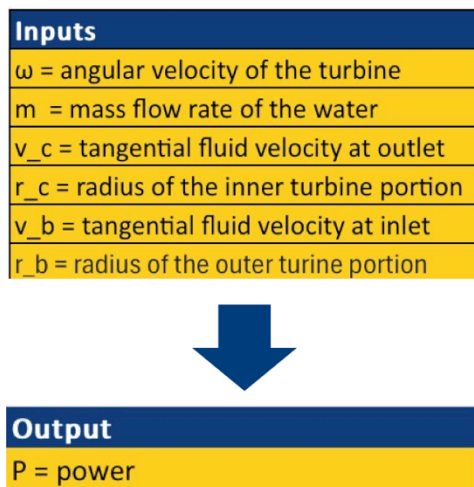

Figure 3: Input and Outputs of Euler’s Turbine Equation

Using all the above the following Matlab code was created:

```

Editor - /Users/jen/Downloads/Turbine_Modeling_function.m
Turbine_Modeling.m x Turbine_Modeling_function.m x +
1 function Power = Turbine_Modeling_function(w,m,r_c,r_b,v_c,v_b)
2 %w = angular velocity
3 %m = mass flow rate
4 %r = radius
5 %v = velocity
6 %c = inner
7 %b = outer
8 Power = 0;
9 Power = w*m*( (v_c*r_c)-(v_b*r_b) );
10 end

```

Figure 4: Matlab Function for Euler's Equation

```

Editor - /Users/jen/Downloads/Turbine_Modeling.m
Turbine_Modeling.m x Turbine_Modeling_function.m x +
1 %w = angular velocity, m = mass flow rate, r = radius
2 %v = velocity, c = inner, b = outer
3 %w,m,r_c,r_b,v_c,v_b
4 Francis = Turbine_Modeling_function (1,1,3,1,1,1);
5 Kaplan = Turbine_Modeling_function (1,1,4,1,1,1);
6 Pelton = Turbine_Modeling_function (1,1,2,1,1,1);
7 F_max = 8;
8 K_max = 10;
9 P_max = 6;
10 eff = [Francis/F_max,Kaplan/K_max,Pelton/P_max];
11
12 x = (1:3);
13 y = [Francis, Kaplan, Pelton];
14 subplot(1,2,1)
15 bar(x,y)
16 xlabel('Francis Kaplan Pelton')
17 title('Power Outputs of Various Turbines')
18 ylabel('Power Output')
19
20 subplot(1,2,2)
21 bar(x,eff)
22 xlabel('Francis Kaplan Pelton')
23 ylabel('Efficiency (in %)')
24 title('Efficiency of Various Turbines')

```

Figure 5: Matlab Code for Output Power of 3 Different Turbines

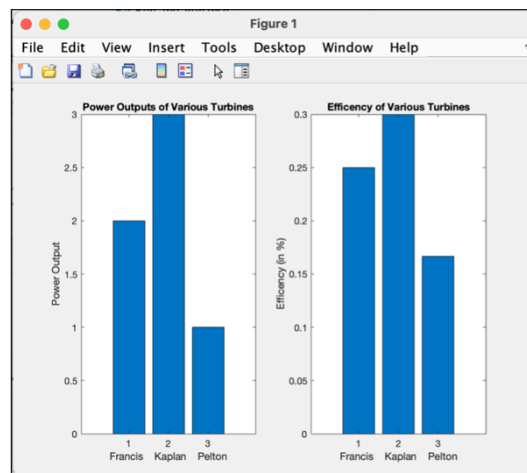

Figure 6: Output Results Comparing 3 Turbines

3.3.1.3 Robert Ginieczki

Given the likelihood that our team will have to construct the project from the ground up, we decided to estimate tunneling costs to better understand the potential impact on site feasibility. Having an initial cost estimate is critical, as tunneling represents a substantial portion of infrastructure expenses, especially for a pumped storage facility. Different site conditions, such as the type of ground or rock encountered, significantly affect the overall cost. Harder rock formations will demand more specialized equipment and longer construction times, which can dramatically increase expenses. Understanding these variables early allows us to anticipate the challenges we may face at potential sites and avoid those that would be financially unfeasible. Additionally, estimating these costs will help us compare the feasibility of various sites and determine whether leveraging existing infrastructure could reduce costs. By factoring these tunneling costs into our early decision-making process, we are ensuring that we avoid costly surprises later in the project timeline. Furthermore, it allows us to explore more efficient construction techniques that could lower costs, making the project more viable within our budget constraints. This proactive approach will help us strategically plan the development phase, allowing for a more practical and cost-effective execution of the design.

$$C_t = \left((1,280 + E_g + 208,500) \times h^{-.54} \times l \right) + (66,429 \times E_g + 17,000,000) \quad [7]$$

C_t = Cost of tunnel in

E_g = Energy capacity in MW

h = Average hydrolic head

l = Shortest distance between upper and lower reservoir

This formula allows us to predict the potential costs more accurately by considering site-specific characteristics. By understanding these factors early, we can explore alternative construction methods and optimize cost-efficiency. This approach not only ensures that our project remains economically feasible but also positions us to make informed decisions about site selection and design, enabling us to proceed with confidence and avoid unnecessary financial risks.

3.3.1.4 Benjamin Tushingham

A big part of our site selection will be done through ArcGIS. Using reservoir data posted by NREL [24], we have potential reservoirs based on rainfall collection and other considerations. These data points include reservoir size and difference in height between the paired reservoirs (the head). The next step is optimizing site selection. The first step is to get rid of sites that are located in national forests as we are unable to build a reservoir there. After doing basic elimination of sites, looking at utilities lines is going to be the next step. This will provide us with information on viewing what utility lines have open capacity. If a line either has capacity or another power plant is being decommissioned, we will save those power lines. If the power line has no opening soon, that whole power line will be out of consideration and deleted from the map. Once that is complete, a raster function will be done comparing the distance between one of the reservoirs and the closest powerline. The acceptable distance will be established once we can get the data. This is our immediate goal in ArcGIS, but it will be used a lot in the future for site selection based on several different equations being put against each other to find the best site. We are still

attempting to find the reservoir location data within the file. Currently we have emailed the ArcGIS majors and have reached out to NREL to see where the stored data is at. Once we get this data, we can start all our optimizations as all the groundwork will be laid out. The next major step is obtaining the location data.

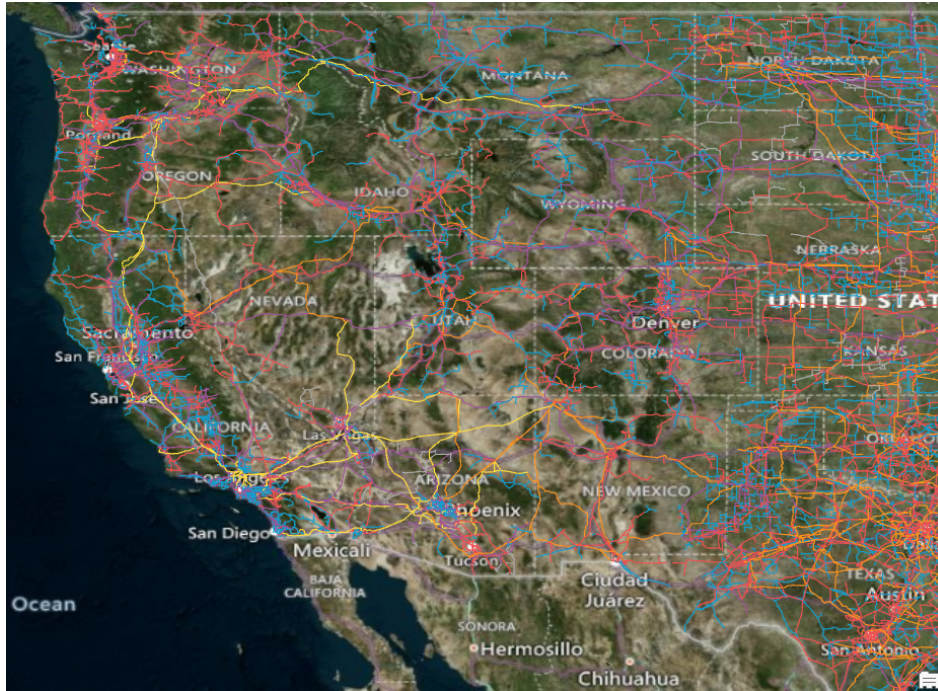

Figure 7: Transmission Lines in US



Figure 8: Reservoir Locations from NREL [24]

4 Design Concepts

4.1 Functional Decomposition

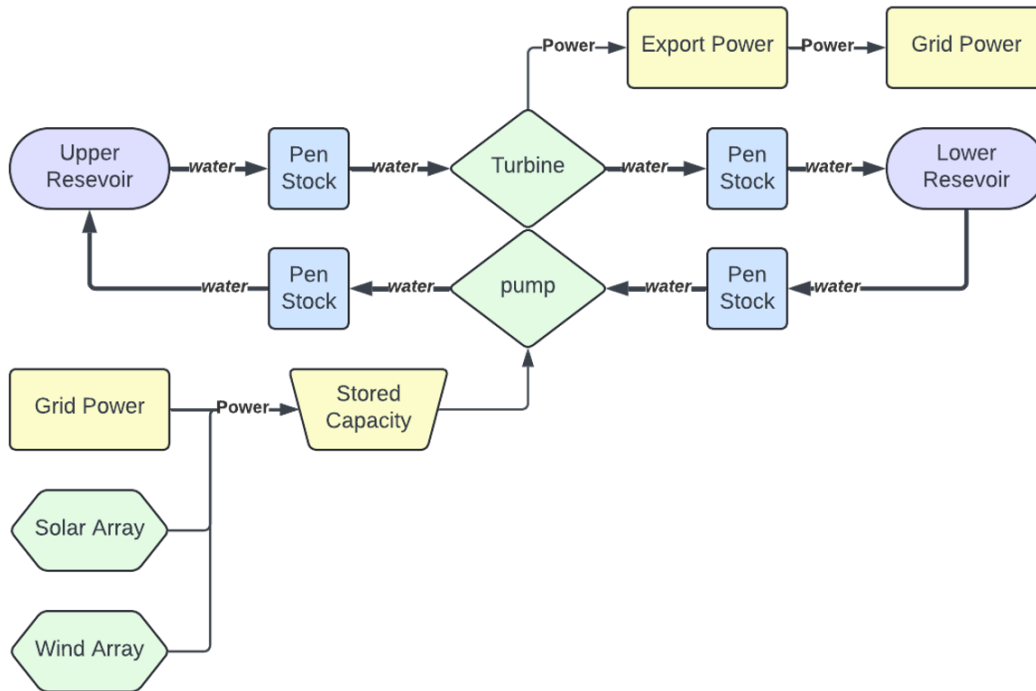

Figure 9: Functional Model

The figure above illustrates how our team’s closed-loop pumped storage hydro facility is designed to achieve the target output of 1 gigawatt of energy. At the heart of this system is the upper reservoir, positioned at a high elevation, which acts as the primary energy storage unit. Water stored here represents potential energy that is converted into kinetic energy as it flows downhill toward the lower reservoir. The water’s movement through turbines in this process generates electricity, and once it reaches the lower reservoir, the cycle can restart. During times when excess energy is available—such as during low demand or peak renewable generation periods—this surplus power is used to pump the water back to the upper reservoir, maintaining a continuous cycle of energy generation and storage.

To further optimize the system's efficiency and sustainability, we have designed it to be compatible with additional renewable energy sources such as solar or wind. Solar panels or wind turbines can be incorporated into the infrastructure to provide extra energy. During times of peak renewable generation, when solar or wind energy production exceeds demand, this excess energy can be used to drive the pumps, allowing the water to be stored at the upper reservoir for future use. This combination ensures that renewable energy, which is often intermittent, can be stored and utilized even during periods when natural conditions aren't ideal—such as nighttime for solar or calm weather for wind.

This flexible functional model is advantageous for our team’s design process, as it ensures that we are well-equipped to address the key components necessary in a closed-loop pumped storage hydro system. It also allows us to adapt the model as we refine future site selections. The ability to alter the renewable energy sources integrated into the system is especially important because site characteristics can vary widely. The model is adaptable, giving our team the ability to fine-tune the design based on the specific conditions of each site, rather than limiting the project to one specific blueprint. This adaptability means we can make the design conform to the site, rather than forcing the site to conform to a predetermined design, enhancing both flexibility and efficiency as we move forward with site selection and system implementation. Additionally, this approach opens the door to potentially new innovations in the design and energy capture mechanisms.

4.2 Concept Generation

For our Concept Generation we used a morphological matrix for the main design concepts. Within the design concepts, there were 4 main components that affected the project's feasibility. One of the main considerations when completing concept generation was the ability to get a company to view our project as a realistic idea that could be built. Within this idea one of the bigger factors is cost. With cost being highly considered we designed different potential designs to try to help keep the cost down.









Concept	Option 1	Option 2	Option 3
Potential for Hybrid Design	Wind	Sun	Wind and Sun
If the site location would allow for energy production through either solar panels or wind turbines			
Construction Options	Build From Scratch	Pre-Existing Reservoir	
If the site requires digging to create the reservoir or if there is pre-existing space to fill with water			
Transmission Lines	<1 miles	<10 miles	>20 miles
Distance from the energy production site to currently available transmission lines			
Power Demands	Decommissioning Utilities	Future Power Line Projects	
Circumstances that would make the demand of energy high (feasibility of the project)			

Figure 10: Morphological Matrix

The first consideration is the type of hybrid design that we are going to use. We narrowed down our options to either wind or solar due to the likely location being near a mountain range. Depending on the site selection using both wind and solar might be beneficial. The next consideration is the construction options. Through research, we found that there is a popular idea to convert old mine shafts into reservoirs

due to them being prebuilt for us. This would save a significant amount in cost as digging our own reservoirs is highly expensive, however, this does bring other problems such as land agreement issues. Whoever the mine shaft is owned by might cause issues with selling or repurposing the site. In addition to this there is environmental aspects that need to be considered. The biggest issue, however, is finding one that would meet all the needed criteria for a closed loop PSH system. There are pros and cons to both design ideas. Building our own reservoirs is a good option due to it producing more potential site locations, but it is much more expensive. The next concept is transmission lines. The location of nearby transmission lines is extremely important for cost and sustainability purposes. Building transmission lines is something that will be required, but we want to build as little as possible. Using more material for new transmission lines is not sustainable when we could use pre-existing lines. Not only is it not sustainable, but it would also increase the total cost of the entire project significantly. The ideal range for transmission lines would be under a mile as the estimate to build overhead transmission lines for one mile is roughly one million dollars. Less than 10 miles is still workable in our design, it would just decrease the desirability of the project design. The last option is above 20 miles, which would be too expensive to justify without cutting cost on something else. For example, if we found a great mine shaft with no transmission lines, it would still be feasible as we are cutting costs elsewhere. The last option is power demand. This will be explained in depth below in the selection criteria section, but I will cover it briefly here. This is the idea of power being needed wherever we are proposing this idea. The two main options would be to find a decommissioning power plant or follow potential designs for transmission lines. Finding decommissioning power plants like coal plants would be the perfect selling point of not only being able to replace the loss of power but replacing it with clean energy. If we are unable to find any sites close to decommissioning power plants, looking at where future transmission lines are being built will save us cost and effort. Not only would we save on transmission line building costs but if there is a proposal for new transmission lines there is likely a need for power. This is ideal since our design brings power to new spots that can require the power demand our design provides.

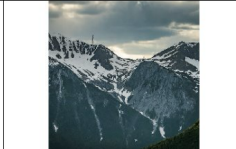
Some other concept generations that are not on the morphological matrix include how many penstocks we are including in our design and if the housing for the turbine is going to be underground or above ground. The penstocks are dependent on the turbine type and if it is reversible or not. If we want our design capable of pumping water back up while creating energy in the turbine, we will need more than one penstock. However, if we have a reversible turbine and do not need them simultaneously flowing up and down then one penstock would work. Another consideration is if we want to house the turbine underground or above ground. Above ground is cheaper and is easier to maintain, due to fixing and working on the turbine being more accessible. While the underground option is better for the environment as to not disturb the wildlife. It also helps to keep the turbine and the housing more protected from the weather. These two options will also depend on site selection as depending on the soil and ground location building the housing underground might not be an option.

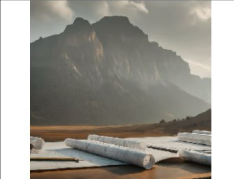
Overall, the concept generation is heavily dependent on-site selection, where cost will play a key factor in which concepts will be selected. We have put together distinctive design potential but depending on what the site provides they could change to adapt to the best site. In other words, if we find a site that is flexible on design ideas we would decide to go with all the cost friendly options to make the design desirable to buyers.

4.3 Selection Criteria

For a Closed Loop PSH system, there are 3 initial selection criterion that our team has focused on. This will be the site selection, power demands, and turbine selection (available power). Though there are multiple other selection criteria to consider when designing a closed-loop pumped storage hydro system, those excluded here will be revisited as they are more individually site dependent. However, a selection criterion that our team is going to work on starting soon is environmental factors. This factor will not be considered until we have selected our top sites, as environmental factors are specific to individual site locations as well.

4.3.1 Site Selection

The first criterion, arguably the most important, is site selection. Within site selection, there are multiple considerations for selecting an appropriate site. The first criterion is a site that will provide a large enough reservoir size to produce/store up to 1 GW of power. The reservoir size needs to be selected based on the deemed necessary power requirement (for the specific site area) to ensure that there is enough potential power through water availability in a 24-hour period. Some of the current calculations that has been done are the following:

$$E_s = V_w \cdot 0.85 \cdot 9.8 \cdot h \cdot \sqrt{0.8} \cdot \frac{1}{3.6} \quad [8]$$

$$V_w = 7.25 \text{ GL}$$

$$h = 580\text{m}$$

$$E_s = 8702 \text{ MWH}$$

This calculation shows the energy storage of an example of a smaller reservoir. This calculation will help to compare sites with their energy storage capabilities. In addition to this the following equation can be used:

$$E_g = \frac{E_s}{t} \quad [9]$$

$$E_s = 8702 \text{ MWH}$$

$$t = 24\text{hr}$$

$$E_g = 362 \text{ MW}$$

362 MW is the energy capacity within a 24-hour period. This can be used to provide us with which sites will be able to meet our required power needs for the area in which it's located. This will tie into decommissioning plants and power demand, which will be discussed below. Along with reservoir size, another key factor is the available head for each reservoir. The head is going to be the measurement of the reservoir height also referred to as the measurement of the mechanical energy in water per unit weight of fluid. Available head within certain reservoirs will also help to guide the design on which turbine will be most effective. Our group also investigated the possibility of using abandoned mine shafts, as these can be converted into reservoirs, and have a bonus of significant cost reduction. However, these sites often do not meet all the criteria. Another important criterion within site selection is going to be the transmission line locations. For cost efficiency, the locations of previously available transmission lines are an important

consideration. Existing transmission lines need to be as close as possible to the site as the lower-end cost to install lines for a mile is over a million dollars. Another crucial factor within site selection is the potential for a hybrid design. Within our design, we want to have at least one method of renewable energy source besides the PSH system. This is going to fall into the following two types: wind and solar. The last major criterion for site selection is going to be based on power demand and power needs. This would essentially relate to the demand for power in the area the site is in. Building a site for a town of 20 is not beneficial to anybody. With this said, we need to ensure that the potential for power is needed in the location we select. There are a few different methods to ensure power is needed. These methods will be talked about in the power demand section below.

4.3.2 Power Demand

The next major selection criterion is the need for power or the power demand. When building any design that produces power there needs to be a place to send it. This means there must be a desire for the power production we are going to create. Some different methods to ensure the site location has a power demand is to select a site near a decommissioning power plant, near a densely populated area, or possibly a vulnerable area to rolling blackouts. So far, most sites will likely have a decommissioning power plant near them, so this is our favorite option. Our team is researching decommissioning coal power plants specifically due to them being closed for their poor effects on the environment. When selecting a site based on a decommissioned coal plant there is an availability of transmission lines and the open spot to fill a significant power production loss. This will help with cost in our design and feasibility of our project. If there is a gap of power production and a site nearby that can replace the energy with clean, renewable energy the project will be at a peak for demand. Our team considered the other two, but due to site selection being slim in densely populated areas it is not a top priority. This can also be said with areas vulnerable to rolling blackouts because these are often also densely populated areas. This section of selection criterion is unfortunately not quantifiable through calculations but through map selection of picking sites and researching possible decommissioning plants. For example, the Four Corners Generating Station that is in the southwest portion of New Mexico would be a great option for any site nearby. This coal plant has already decommissioned units 1-3 in 2013 and plans to decommission units 4 and 5 in 2031. These two remaining units produce around 1540 MW worth of power. Meaning that our PSH system could easily replace the power output of this coal plant. The only applicable equation would be:

$$P_g > P_r \quad [10]$$

The above equation is a requirement when looking at decommissioning power plants. The term on the left represents the power our system is going to generate and the term on the right represents the power that is required to be a good replacement of a decommissioning power plant. Our team needs to ensure that the plants we are looking at produce less power than our PSH system can produce. If we select a power plant that produces triple what our system produces it would not be a feasible option to implement it in place of the closing power plants. The following equation will also be useful when considering power demand and output.

$$P = T \cdot RPM \cdot \frac{2\pi}{60} \quad [11]$$

In the following equation the P on the left is power, which is in watts. This is all equal to torque multiplied by rpm multiplied by two pi over 60. This equation was initially used to solve for the potential torque we will need, but this can also be used to solve for the required rpm as well. The calculation below

will show the required torque.

$$1,000,000,000 = T \cdot 850rpm \cdot \frac{2\pi}{60}$$

$$T = 11.6 \text{ million Nm}$$

This calculation is a helpful representation of how much torque is going to be needed to produce our desired output. This is a big part of power demand because depending on our hybrid design, we will need to increase or decrease the number on the left.

4.3.3 Turbine Selection

The next portion of selection criteria is the turbine type. The type of turbine can be selected based on the site or can be a site selection criterion. Fortunately, for the turbine selection there is quite a bit of leniency that can be had for choosing a site. The turbine selection is essential to ensuring we produce enough power in a certain time. However, with that said, there are multiple different selection criteria for the turbine. The three types of turbines that our team has been researching are the Kaplan, Francis, and Pelton. The Kaplan and Francis turbine are reaction turbines, whereas the Pelton is an impulse turbine. The main difference between impulse and reaction turbines is the types of energy used to rotate the turbine. Impulse uses only the kinetic energy of the water to rotate the turbine, and reaction uses both kinetic and pressure energy to rotate the turbine. The Francis is the most common type of turbine found in hydropower due to its better performance in high head situations. Another benefit of the Francis turbine is its capabilities to be reversible. If we decide to only have one penstock, our method of water flowing both down and up the same pipe a reversible turbine would be required. The Kaplan turbine has more adjustable capabilities like the blades and wicket gates. However, the Kaplan turbine is not reversible, so it would require more than one penstock. The Kaplan turbine is also used in medium head situations. The Pelton turbine is used for high head situations with low flow. This type of turbine also has the highest efficiency rate out of the three types. For the selection criteria we also have a mathematical model through Matlab that will help us to easily select sites based on the capabilities of any of the three turbines producing enough power. This is also beneficial in deciding which of the three turbine types produces the most power for our top picked sites. The mathematical model will help narrow down sites and turbine types with predicting the efficiency and power output. In addition to this it will also help to refine the required power needed by the hybrid design.

4.3.4 Conclusion

Overall, there are many different criteria that will/are going into selection criteria for finalizing our design. There are three main criterion that have been focused on when selecting multiple parts of our design. The next portion of concept selection within the next few weeks is going to be finding our top three site selections and the technical specifications that will work best with our selections.

4.4 Concept Selection

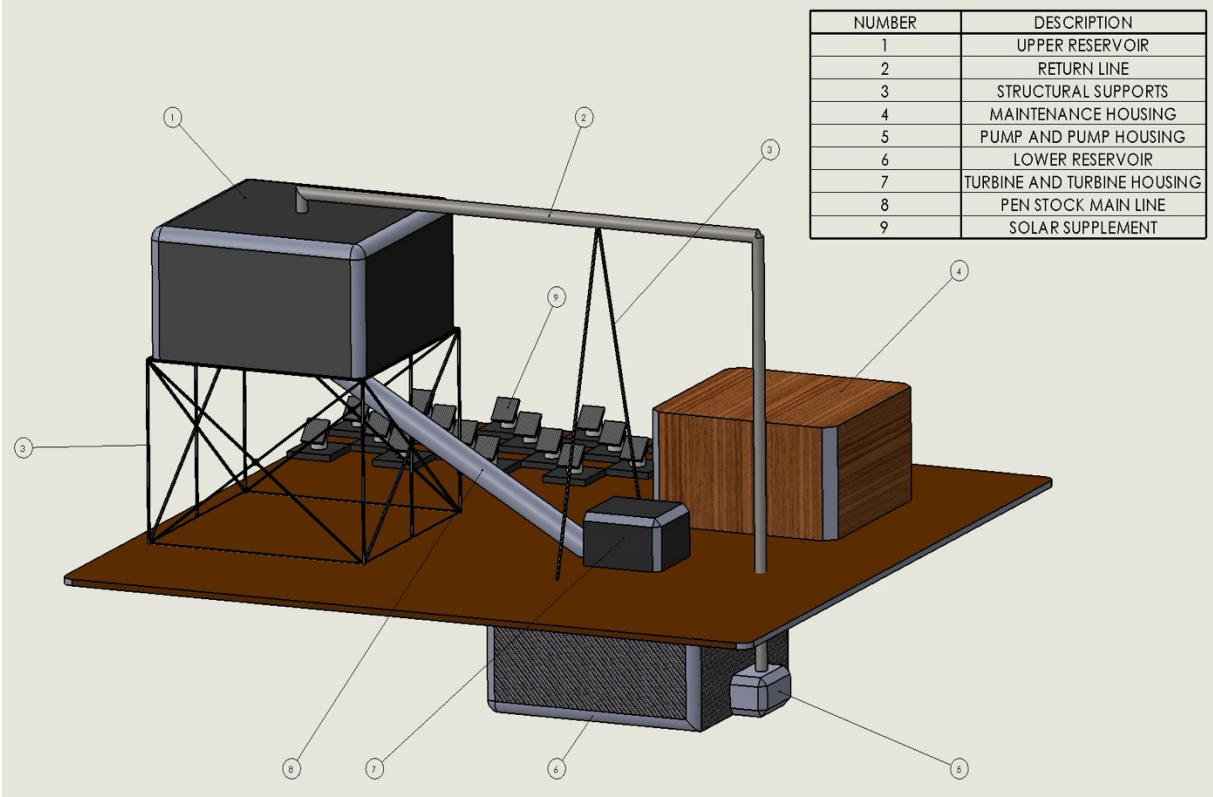

Figure 11: Current CAD Model

Pugh Chart - Hydropower Collegiate Competition				
		Concept		
		1	2	3
		Design 1	Design 2	Design 3
Criteria	Energy Production	+	datum	+
	Tolerable Head	0		+
	Average Efficiency	0		0
	Reversibility	0		0
	Cost	-		--
	Generation Power	0		+
	Environmental	-		--
Sum of +'s		1		3
Sum of -'s		2		4
Sum of 0's		5		0
Total		-1		-1

Figure 12: Pugh Chart

The images above illustrate the team’s CAD model and Pugh chart. The rationale behind choosing design 2 as the baseline for our project is based on three essential aspects of the overall design. First, the design must address the need for energy replacement due to the planned decommissioning of nearby power plants. Our team strategically identified areas where decommissioned facilities could drive demand for new energy sources, creating an opportunity for the implementation of our closed-loop PSH system. Second, we factored in the total development and construction costs associated with the facility. In this context, we explored two scenarios: building the system from the ground up or adapting existing reservoirs, such as repurposing mine shafts for reservoirs and penstock. Utilizing pre-existing

infrastructure would substantially lower the overall project cost. Third, the distance from the selected site to nearby transmission lines was another major consideration, as it directly impacts the project's financial viability. With transmission line costs averaging \$1 million per mile, a site with perfect geological conditions could be ruled out if it is located too far from available transmission networks. By centering our decision-making on these three factors, we have optimized the design process, reducing unnecessary challenges and ensuring our project remains feasible and cost-effective. This structured approach has been critical in guiding us toward efficient project development without wasting resources on impractical solutions.

4.4.1 Design 1:

- **Energy Source:** Relies on solar energy.
- **Construction Approach:** This design involves building the facility entirely from scratch, which implies a higher upfront investment in construction.
- **Proximity to Transmission Lines:** Located less than 10 miles away from existing transmission infrastructure, which is moderately accessible but still involves some connection costs.
- **Decommissioning Consideration:** The site is near decommissioning utilities, making it a suitable candidate for replacing older energy sources with renewable solar power.

Key Considerations: This option focuses on solar power and is located reasonably close to transmission lines. Building from scratch increases the costs but offers a long-term opportunity for replacing legacy energy sources. However, relying exclusively on solar energy can present challenges due to variability in sunlight based on the site's geographic location and weather conditions.

4.4.2 Design 2:

- **Energy Source:** Wind energy.
- **Construction Approach:** This design uses an existing reservoir, which greatly reduces construction time and cost.
- **Proximity to Transmission Lines:** Less than 1 mile from existing lines, making it the most cost-effective in terms of connection. Additionally, future power line developments are planned, which adds further reliability.
- **Decommissioning Consideration:** Although there's no specific mention of nearby decommissioning utilities, the site's proximity to upcoming transmission projects makes it a viable long-term solution.

Key Considerations: This option focuses on wind energy and takes advantage of existing infrastructure, making it the most financially feasible and efficient choice. The close location to transmission lines and future power projects gives it a strong advantage in terms of accessibility and grid connection. The reliance on wind power also adds stability, depending on the site's wind availability.

4.4.3 Design 3:

- **Energy Source:** A combination of wind and solar power (hybrid system).
- **Construction Approach:** Requires building the facility from scratch, which entails higher costs and a longer timeline.
- **Proximity to Transmission Lines:** Located more than 20 miles from transmission lines, which dramatically increases the cost of connection (approximately \$1 million per mile of new transmission lines).
- **Decommissioning Consideration:** The site is located near decommissioning utilities, offering potential for replacing outdated energy production with a hybrid renewable approach.

Key Considerations: This design offers a combination of solar and wind energy, making it more resilient to fluctuations in energy generation. However, its distance from transmission lines significantly increases costs, and building from scratch adds to the overall expense, making it the costliest of the three options.

4.4.4 Conclusion:

- **Most Cost-Efficient:** Design 2 emerges as the most economical choice, benefiting from the use of existing infrastructure and close proximity to transmission lines, thus minimizing construction and connection expenses.
- **Most Flexible Energy Generation:** Design 3 provides flexibility with its hybrid energy generation from both wind and solar, but it also involves the highest construction and transmission connection costs.
- **Best Fit for Decommissioning Sites:** Design 1 and Design 3 are strong candidates for replacing decommissioned utilities. However, Design 1 stands out for having lower transmission line costs, making it a more practical choice in the short term.

Overall, Design 2 appears to be the most efficient and feasible option, while Design 3 offers the most energy flexibility at a higher price. Design 1 balances proximity to transmission lines with renewable energy options, but lacks the dual-energy advantage seen in Design 3

5 CONCLUSIONS

Over the course of this semester, our team dedicated significant effort toward designing a closed-loop pumped storage hydro system for the Hydropower Collegiate Competition. This project required the development of a system capable of generating up to 1 GW of power while ensuring minimal environmental disruption and utilizing cost-effective solutions. The design we proposed revolves around using two separate reservoirs at different elevations, where water is pumped to the higher reservoir to store energy and then released through turbines to generate electricity. One of the critical focuses of our design process was the selection of an optimal site and the integration of renewable energy sources like solar and wind to further enhance the system's sustainability and efficiency.

After thorough evaluation, our final solution proposes the use of existing mine shafts as reservoirs, which helps significantly reduce construction costs. Additionally, we incorporated renewable energy sources into the design to maximize energy output and minimize reliance on traditional grid power. This hybrid

design ensures that energy is both stored and produced efficiently, meeting the project's sustainability goals. The decision-making process was supported by a combination of engineering tools, including CAD models and Pugh charts, which helped identify and compare different design options.

By using advanced software for site selection and energy modeling, we were able to ensure that our final design is not only practical but also competitive. The project successfully meets the established requirements, addressing critical concerns like energy production, environmental impact, and budget constraints. Our team's final design offers a balanced and feasible solution, positioning it as a strong candidate in the competition and setting the groundwork for future development in pumped storage hydropower technology.

6 REFERENCES

- [1] W. D. Caster Jr., D. G. Rethwisch. "Material Sciences and Engineering". Danvers, MA: McGraw-Hill Education, 2000. ISBN-13: 9781119321590
- [2] R. G. Budynas, J. K. Nisbett. "Shigley's Mechanical Engineering Design". New York, NY: John Wiley and Sons, Inc., 2020. ISBN-978-0-07-339821-1
- [3] Y. Liu, T. Yen, T Hsu. "Abrasion erosion of concrete by water-borne sand". *Cement and Concrete Research*, vol. 36, issue 10, 2006, pages 1814-1820, ISSN 0008-8846, <https://doi.org/10.1016/j.cemconres.2005.03.018>.
- [5] N. Hao, X. Li, Y. Li, J. Jia, L. Gao. "A novel reliability-based method of calibrating safety factor: Application to the cemented sand and gravel dams". *Engineering Geology*, vol. 306, 2022, ISSN 0013-7952, <https://doi.org/10.1016/j.enggeo.2022.106719>.
- [6] E. Sayed-Ahmed, A. Abdelrahman, R. Embaby. "Concrete dams: thermal-stress and construction stage analysis". *Dams and Reservoirs*, vol. 28 issue 1, pp. 12-30. March, 2018. E-ISSN 1756-8404. [Online]. Accessed September 15, 2024. Available: <https://doi.org/10.1680/jdare.16.00055>
- [7] Y. Ghanaat. "Failure Modes Approach to Safety Evaluation of Dams". 13th World Conference on Earthquake Engineering, Vancouver, CA, paper no. 1115. Accessed Sept. 15, 2024. [Online]. Available: <http://queststructures.com/publications/13WCEE-Paper.pdf>
- [8] J. Laue, and S. Knutsson, 'Dam Safety and Dams Hazards', *Journal of Earth Sciences and Geotechnical Engineering*, vol. 10, no. 6, pp. 23–40, 2020.
- [9] F. M. White and H. Xue, *Fluid Mechanics*. New York, NY: McGraw-Hill, 2021
- [10] P. Breeze, "Chapter 8 - Hydropower," in *Power Generation Technologies (Second Edition)*, Newnes, 2014, pp. 153–179
- [11] J. I. Pérez-Díaz, M. Chazarra, J. García-González, G. Cavazzini, and A. Stoppato, "Trends and challenges in the operation of pumped-storage hydropower plants," *Renewable and Sustainable Energy Reviews*, vol. 44, pp. 767–784, Apr. 2015. doi:10.1016/j.rser.2015.01.029
- [12] T. R. Simon *et al.*, "Life cycle assessment of closed-loop pumped storage hydropower in the United States," *Environmental Science & Technology*, vol. 57, no. 33, pp. 12251–12258, Aug. 2023. doi:10.1021/acs.est.2c09189
- [13] C. Trivedi, M. Cervantes, and O. Dahlhaug, "Experimental and numerical studies of a high-head Francis Turbine: A review of the Francis-99 Test Case," *Energies*, vol. 9, no. 2, p. 74, Jan. 2016. doi:10.3390/en9020074
- [14] E. Engineeringtoolbox, "Hydropower," Engineering ToolBox, https://www.engineeringtoolbox.com/hydropower-d_1359.html (accessed Sep. 14, 2024).
- [15] "Types of hydropower turbines | Department of Energy," Department of Energy, <https://www.energy.gov/eere/water/types-hydropower-turbines> (accessed Sep. 15, 2024).
- [16] D. Smith, J. Hartmann, and R. Kvam, "Hydropower Communications and consultation," Hydropower Sustainability Alliance, (accessed Oct. 20, 2024).

- [17] "The Euler Turbine Equation," 12.3 the Euler turbine equation, <https://web.mit.edu/16.unified/www/FALL/thermodynamics/notes/node91.html> [accessed Oct. 4, 2024].
- [18] B. C. Punmia, Ashok Kumar Jain, and Arun Kumar Jain, Soil mechanics and foundations. Delhi: Laxmi Publications (P) Ltd., , C, 2005.
- [19] "Closed-Loop Pumped Storage Hydropower Resource Assessment for the United States Final Report on HydroWIREs Project D1: Improving Hydropower and PSH Representations in Capacity Expansion Models," 2022. Available: <https://www.nrel.gov/docs/fy22osti/81277.pdf>
- [20] "2021 Pumped Storage Hydro Report," 2021. Available: 2021-Pumped-Storage-Report-NHA.pdf (hydro.org)
- [21] S. Lake, "FINAL ENVIRONMENTAL IMPACT STATEMENT FOR HYDROPOWER LICENSE," 2019. Accessed: Sep. 17, 2024. [Online]. Available: <https://www.ferc.gov/sites/default/files/2020-06/01-25-19-FEIS.pdf>
- [22] "Federal Energy Regulatory Commission Engineering Guidelines for the Evaluation of Hydropower Projects," 2017. Accessed: Sep. 17, 2024. [Online]. Available: <https://www.ferc.gov/sites/default/files/2020-04/Chap14AppendixH.pdf>
- [23] "Bath County Pumped Storage Station | Dominion Energy," [www.dominionenergy.com. https://www.dominionenergy.com/projects-and-facilities/hydroelectric-power-facilities-and-projects/bath-county-pumped-storage-station](https://www.dominionenergy.com/projects-and-facilities/hydroelectric-power-facilities-and-projects/bath-county-pumped-storage-station)
- [24] "Closed-Loop Pumped Storage Hydropower Supply Curves," [www.nrel.gov. https://www.nrel.gov/gis/psh-supply-curves.html](https://www.nrel.gov/gis/psh-supply-curves.html)
- [25] F. A. Diawuo and R. T. Amanor, "Need for pumped hydro energy storage systems," in Pumped Hydro Energy Storage for Hybrid Systems, A. T. Kabo-Bah, F. A. Diawuo, and E. O. Antwi, Eds. Academic Press, 2023, pp. 23-41. doi: 10.1016/B978-0-12-818853-8.00001-7
- [26] Federal Energy Regulatory Commission, "Final Environmental Impact Statement for the Mountain Valley Pipeline Project," Federal Energy Regulatory Commission, Jan. 25, 2019. [Online]. Available: <https://www.ferc.gov/sites/default/files/2020-06/01-25-19-FEIS.pdf>. [Accessed: Sep. 16, 2024].
- [27] Voith, "Francis Turbines," Voith, 2018. [Online]. Available: https://voith.com/corp-en/VH_Product-Brochure-Francis-Turbines_18_BDI_VH3369_en.pdf. [Accessed: Sep. 16, 2024].
- [28] W. Zhao, A. Presas, M. Egusquiza, D. Valentín, E. Egusquiza, and C. Valero, "Increasing the operating range and energy production in Francis turbines by an early detection of the overload instability," Measurement, vol. 181, p. 109580, 2021. doi: 10.1016/j.measurement.2021.109580.
- [29] U.S. House of Representatives, "Report on the Activities of the Committee on Energy and Commerce for the One Hundred Fifteenth Congress," U.S. Government Publishing Office, Washington, DC, Rep. 115-458, 2018. [Online]. Available: <https://www.govinfo.gov/content/pkg/CRPT-115hrpt458/pdf/CRPT-115hrpt458.pdf>. [Accessed: Sep. 16, 2024].

- [30] "Design features of the Helms pumped storage project," IEEE Xplore, pp. 10-12. [Online]. Available: <https://www.ieee.org>. [Accessed: Sep. 16, 2024].
- [31] N. Fitzgerald, R. Lacal Arántegui, E. McKeogh, and P. Leahy, "A GIS-based model to calculate the potential for transforming conventional hydropower schemes and non-hydro reservoirs to pumped hydropower schemes," *Energy*, vol. 41, no. 1, pp. 483-490, 2012. doi: 10.1016/j.energy.2012.02.044. [Accessed: Sep. 16, 2024].
- [32] Federal Energy Regulatory Commission, "Final Environmental Impact Statement for the Mountain Valley Pipeline Project," Federal Energy Regulatory Commission, Jan. 25, 2019. [Online]. Available: <https://www.ferc.gov/sites/default/files/2020-06/01-25-19-FEIS.pdf>. [Accessed: Sep. 16, 2024].
- [33] SL Energy Storage, "Swan Lake Energy Storage Project Overview," *Swan Lake Energy Storage*, 2023. [Online]. Available: https://slenergystorage.com/documents/SwanLake_Information_November2023.pdf. [Accessed: Sep. 16, 2024].
- [34] Rye Development, "Projects - Swan Lake and Goldendale Pumped Storage Projects," *Rye Development*, 2023. [Online]. Available: <https://www.ryedevelopment.com/projects.html>. [Accessed: Sep. 16, 2024].
- [35] National Hydropower Association, "Closed-Loop Pumped Storage Hydropower Motivations and Considerations," *National Hydropower Association*, 2018. [Online]. Available: <https://www.hydro.org>. [Accessed: Sep. 16, 2024].
- [36] Klamath County, "Swan Lake Pumped Storage Project - Presentation to County Commissioners," *Choose Klamath*, Aug. 2020. [Online]. Available: https://www.chooseklamath.com/wp-content/uploads/2018/09/Swan-Lake-Pumped-Storage-Presentation_County-Comissioners-08202018.pdf. [Accessed: Sep. 16, 2024].